

High Temperature Microbalance Sensor Crystals

Type R-30



R-30 sensor crystals are optimized for use in thin film deposition systems at higher temperatures, as required in PVD, CVD, ALD and OLED. The crystals are temperature compensated at around 500°C (932°F) and enable precise measurements from 300°C – 800°C (572°F – 1472°F). The electrode design is compatible with the industrial standard (Inficon, Maxtec, Sycon and Sigma).

BENEFITS

- Excellent frequency stability from 300°C up to 800°C (572°F to 1472°F)
- High temperature stability up to 850°C (1562°F)
- electrode design compatible with industry standard
- high Q factor around 70000

SPECIFICATIONS

Resonant frequency	5.8 ± 0.1 MHz
Piezoelectric crystal	GaPO ₄ (gallium phosphate) single crystal
Diameter	13.97 mm (0.550 inch)
Thickness	0.2 mm (0.008 inch)
Sensitivity	≈ 0.3 ng/Hz
Frequency – temperature behavior	$f_s(T) = f_s(T_0) [1 + a(T - T_0) + b(T - T_0)^2 + c(T - T_0)^3]$
T ₀ , a, b, c	505°C (941°F), 0.00831 ppm/°C, - 0.00186 ppm/°C ² , 8.5·10 ⁻⁶ ppm/°C ³
Front side	fully metallized, flat
Back side	double anchor, curvature = 2 dioptre (R = 265 mm)
Electrode material (T < 800°C)	platinum on Ti (adhesion layer)
Surface	fine lapped (#4000)
Dynamic resistance R ₁	< 10 Ohm
Dynamic capacitance C ₁	0.08 pF
Static capacitance C ₀	32 pF

Resonator dimensions

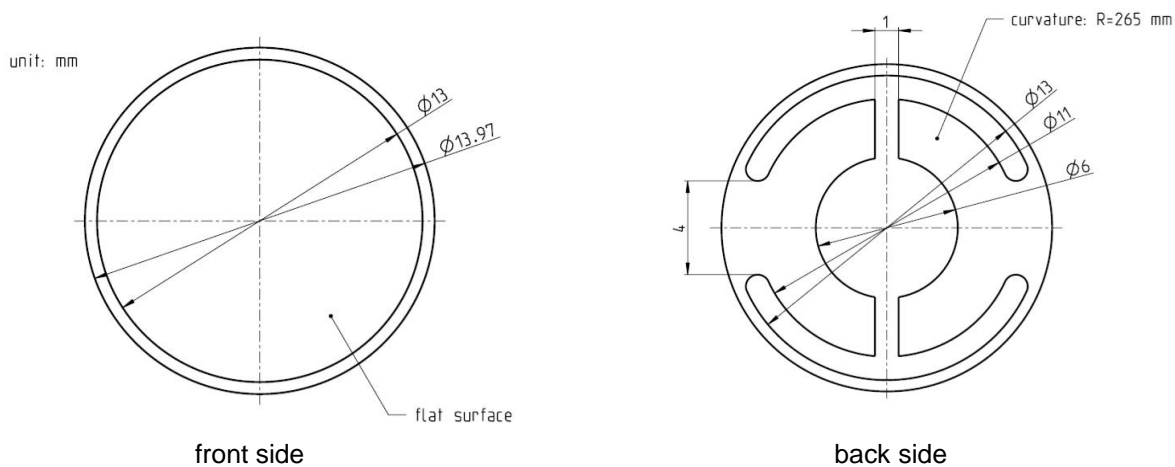

Frequency Temperature dependence

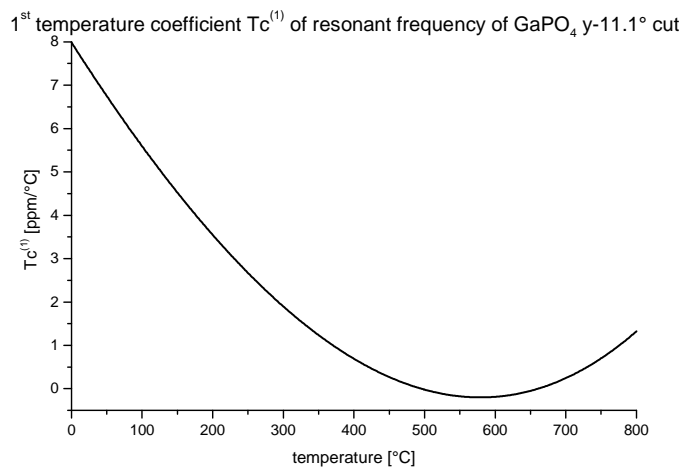
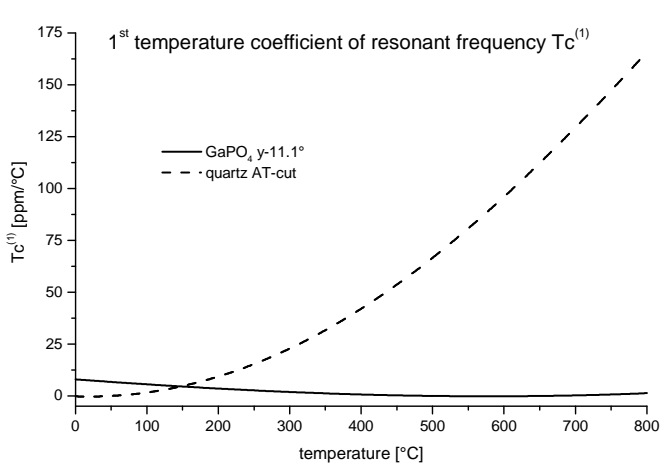

Modifications (on request)

- wrapped around electrode design (both contacts at back side)
- custom specified temperature compensation from -50°C up to 650°C (-58°F to 1202°F)
- electrode material
- shape of resonator (plano-convex, beveled, plano-plano, biconvex ...)

Piezocryst reserves the right to change specifications and accessories without notice.